



为客户创造价值 为环保贡献力量

高端溶剂回收机的领航者

The leader of high-end solvent recovery machine

整机保修三年，为您打造良心设备

Three year warranty for the entire machine, creating a conscientious equipment for you

中山市杰兴环保设备有限公司

Zhongshan Kit Hing Environmental Equipment Co.,Ltd.

地址：广东省中山市三乡镇乌石村莲塘上路1号

Address: 2F,1F,1, Liantang Sheung Road, Wu Shek Tsuen, San Heung Town,
Zhongshan,Guangdong, China 528463

网址: www.jxep.net www.gdjxhb.com

Email: mashehui@163.com

电话: 0760-85882008 售前技术支持: 13824710232

中山市杰兴环保设备有限公司

Zhongshan Kit Hing Environmental Equipment Co.,Ltd.

公司简介 Company Profile



中山市杰兴环保设备有限公司成立于 2010 年，是一家专业生产，销售溶剂回收设备，高污染废水蒸馏设备，低温蒸馏设备的企业，公司专注于防爆型蒸馏设备，低温蒸馏设备，为大、中、小型企业提供溶剂回收，污水蒸馏等技术服务及设备。

我们以专业的技术，用心的服务，为客户提供安全、优质的防爆环保设备，为客户创造更大的价值，赢得不同客户的支持，公司生产的溶剂回收机有智能安全型和 PLC 全自动型回收机，设备分别取得国家级整机防爆认证，欧美 CE 认证，诚信服务 3A 级认证，由保险公司承保产品责任险。溶剂回收设备并与美国公司合作，与美国公司共同研发高品质的溶剂回收机。

公司自成立以来一直秉承诚信、严谨、开拓创新的精神，立足于市场，坚持以人为本、互惠互利、勇于创新的宗旨，把客户的需求放在第一位，为客户提供各种非标定制与特殊的溶剂回收及蒸馏设备，得到了客户的广泛支持与信赖，愿中山市杰兴环保设备有限公司能和您携手并进共创辉煌。

Zhongshan Kit Hing Environmeant Equipment Co.,Ltd. was established in 2010. It is a professional enterprise that produces and sells solvent recovery equipment, high pollution wastewater distillation equipment, and low-temperature distillation equipment. We focuses on explosion-proof distillation equipment and low-temperature distillation equipment, providing technical services and equipment such as solvent recovery and sewage distillation for large, medium, and small enterprises.

We provide customers with safe and high-quality explosion-proof and environmental protection equipment with professional technology and attentive service, creating greater value for customers and winning the support of different customers. The solvent recovery machines produced by us include intelligent safety and PLC fully automatic recovery machines, which have obtained national level explosion-proof certification, European and American CE certification, and 3A level integrity service certification. The product liability insurance is underwritten by insurance companies. Collaborating with American companies to develop high-quality solvent recovery equipment.

Since its establishment, We has always adhered to the spirit of integrity, rigor, and innovation, based on the market, adhering to the purpose of people-oriented, mutual benefit, and daring to innovate. We prioritize customer needs and provide customers with various non-standard customized and special solvent recovery and distillation equipment, which has received widespread support and trust from customers. We hope that JXEP can work hand in hand with you to create brilliance.

诚信 安全 品质
Integrity Safety Quality

企业愿景 Corporate Vision

让中国的雾霾天少一点，企业的污染小一点，成为企业高危废水处理的优秀供应商，做全球更安全的溶剂回收设备。

Reduce the haze in China and reduce the pollution of enterprises, becoming an excellent supplier for high-risk wastewater treatment, and developing safer solvent recovery equipment globally.

企业使命 Corporate mission

为企业提供安全，环保的设备，使企业都能绿色生产，以科技及创新改善生存环境！

To provide safe and environmentally friendly equipment for enterprises, so that they can all produce green, and improve their living environment through technology and innovation!

企业目标 Business Goals

溶剂回收、安全运行！一直是杰兴不断更新的宗旨

杰兴自成立以来一直把客户的安全及使用便捷性放在首位。经过多年的研发和实践，杰兴已成为行业中更新最快、销量较大并遍布全球的一家公司，为全球企业提供更安全，品质更好的节能环保设备。我们一直在努力帮助客户解决成本与环保的问题

Solvent recovery, safe operation! Always the purpose of JXEP continuous updates

Since its establishment, JXEP has always prioritized customer safety and convenience of use. After years of research and practice, JXEP has become the fastest updating, best-selling and globally distributed company in the industry, providing safer and better quality energy-saving and environmental protection equipment for global enterprises. We have been working hard to help customers solve cost and environmental issues



我们能为您解决的问题 WE CAN SOLVE THE PROBLEM FOR YOU!

01 客户在生产过程中用溶剂或水清洗产品，脏下来的溶剂如何处理？ 哪些可以回收？

How to handle the dirty solvent used by customers to clean products with solvents or water during the production process? What can be recycled?

- | | |
|---|--|
| 1. 含油漆，油墨的液体 | 2. 含油含溶剂的液体 |
| 4. 含松香，固体粉末的液体 | 3. 含树脂胶粘剂的液体 |
| 5. 清洁产品，清洗设备的液体 | 6. 含水含溶剂的液体 |
| 1. Liquids containing paint and ink | 2. Liquids containing oil and solvents |
| 4. Liquid containing rosin and solid powder | 3. Liquid containing resin adhesive |
| 5. Cleaning products and cleaning equipment liquids | 6. Liquids containing water and solvents |

02 问题分析：

Problem analysis:

1、成本问题：

在使用化工的行业中，随着国际原油的不断上涨，溶剂的成本在十年间翻了几倍，如果能将我们现在使用溶剂量减少或溶剂能循环使用，势必可减少生产的一部分成本，假如一天用 300 公斤左右的溶剂，一公斤按 10 元计算，一天我们将节约到 3000 元的支出，一个月即可节约近 10 万的成本。

2、环保问题：

随着中国环保越来越严，每一吨的废液处理费，也由 3000 元涨到 5000 元以上，如果能将脏下来的液体回收，残渣交由环保公司处理，可算贵公司一年能节约多少成本。

1. Cost issue:

In the chemical industry, with the continuous increase of international crude oil, the cost of solvents has doubled in ten years. If we can reduce the amount of solvents we currently use or recycle them, we will inevitably reduce a part of the production cost. If we use about 300 kilograms of solvent per day, calculated at ¥ 10 CNY per kilogram, we will save ¥ 3000 CNY in expenses per day, and can save nearly ¥ 100000 CNY in costs in one month.

2. Environmental issues:

With the increasingly strict environmental protection measures in China, the cost of treating each ton of waste liquid has increased from ¥ 3000 CNY to over ¥ 5000 CNY. If you can recycle the dirty liquid and entrust the residue to an environmental protection company for treatment, how much cost can your company save in a year.

03 解决方法： Solution:

杰兴溶剂回收设备采用间接加热蒸馏法，和低温蒸馏法回收溶剂或废水，本公司一直致力于设备的安全性能，节能性和操作便捷性，在第二代和第三代的基础上增加欧姆龙温控、中文显示界面、压力控制系统等安全配置，主旨是让设备能更自动化运行，安全性能更高减少设备的安全隐患，减少工人的劳动强度。杰兴溶剂回收设备，10 多年来，经产品不断升级，先后推出双系统回收机、连续型回收机、PLC 定制型回收机、智能安全型溶剂回收机等，结合德国技术，制造出中国高品质溶剂回收机，为企业成本节约及环保提供全面保障！

JXEP solvent recovery equipment adopts indirect heating distillation method and low-temperature evaporation retention method to recover solvents or wastewater. Our company has always been committed to the safety performance, energy conservation, and easy operation of the equipment. On the basis of the second and third generations, we have added safety configurations such as Omron temperature control, Chinese display interface, and pressure control system. The main purpose is to make the equipment more automated, improve safety performance, and reduce safety hazards, Reduce the labor intensity of workers. JXEP solvent recycling equipment has been continuously upgraded for over 10 years, and has successively launched dual system recycling machines, continuous recycling machines, PLC customized recycling machines, intelligent and safe solvent recycling machines, etc. Combined with German technology, we have manufactured high-quality solvent recycling machines in China, providing comprehensive guarantees for cost savings and environmental protection for enterprises!



我们专注于更安全和高品质的溶剂回收设备
We focus on safer and higher quality solvent recovery equipment

T-430 低温蒸馏设备 (在真空条件下流出溶剂)

Cryogenic distillation equipment



含4个系列
T-125 T-260 T-430 T-600

型号 Model	进料容量 Feed capacity	回收率 Rate Of Recovery	工作时间 Working Hours	重量 Weight	设备尺寸 Equipment size
T-125	125L	95%~98%	4-12H	250KG	1580*1030*1790mm
T-260	250L	95%~98%	4-12H	850KG	3337*1358*2783mm
T-430	≥ 400 ~ 430L	95%~98%	4-12H	1200 ~ 1500KG	3264*1600*3150mm
T-600	600L	95%~98%	4-12H	1500KG	2750*1768*3400mm

产品介绍:

此设备为新款溶剂回收设备：低温蒸馏溶剂，高真空，在真空条件下流出溶剂，无需真空储罐，可实现 24-48 小时连续进出料，自动排渣功能，例如：蒸馏甲苯只需加热温度为 50-60° C，可回收 300° C 以内的溶剂。可配置氮气保护装置，是碳氢蒸馏回收机最佳的选择，同时也可以应用于涂料，油墨，洗枪水等各种溶剂，此设备与德国设备同款制造，设备设计加热温度 50-200 度，根据防爆要求严格打造，是目前国内较为高配的一款性价比机型。

Product Introduction:

This equipment is a new type of solvent recovery equipment: low-temperature distillation solvent, high vacuum, solvent flows out under vacuum conditions, without the need for a vacuum storage tank, can achieve continuous feeding and discharging for 24-48 hours, automatic slag discharge function. For example, Distilling toluene only requires heating at a temperature of 50-60 ° C, and solvents up to 300 ° C can be recovered, and can be equipped with a nitrogen protection device. It is the best choice for hydrocarbon distillation recovery machines, and can also be applied to various solvents such as coatings, inks, and gun washing water, This equipment is manufactured in the same function as German equipment, with a designed heating temperature of 50-200°C. It is strictly designed according to explosion-proof requirements and is currently one of the more high-end cost-effective models in China.

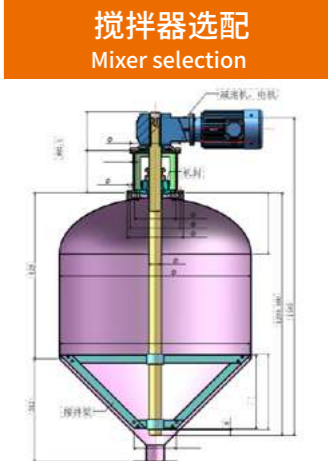

溶剂回收流程图 Solvent recovery process diagram

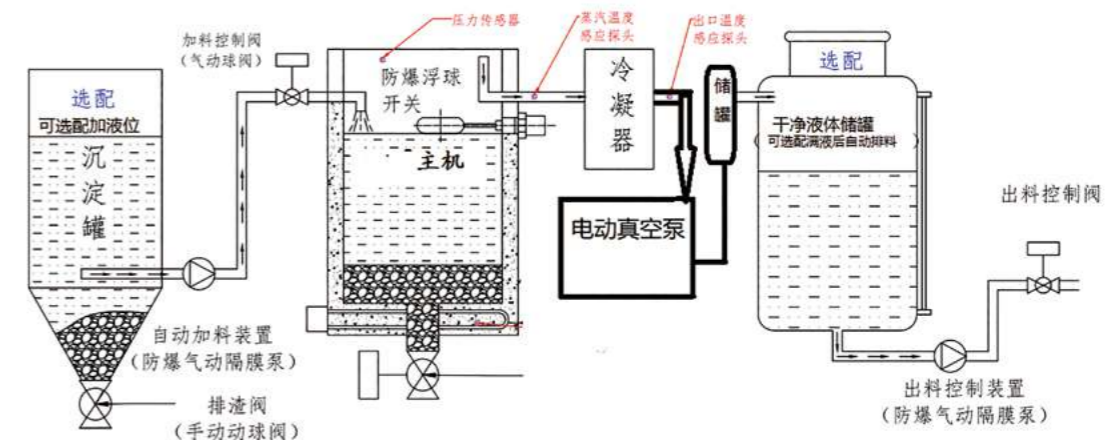

回收流程:

- 1: 单次型回收 (一次进料，回收后停机)
- 2: 连续型回收 (一键启动，自动进料，流出溶剂后自动补料，根据客户工作时间循环回收并停机)
- 3: 定制化回收 (可根据客户选择配备氮气保护装置、增加废液槽和干净液体槽的液位控制，并自动化输送液体等)

Recycling process:

- 1: Single cycle recycling (one feed, shutdown after recycling)
- 2: Continuous recycling (automatic feeding after pneumatic operation, automatic replenishment after liquid outflow, and circular recycling)
- 3: Customized recycling (liquid level control can be added to waste liquid tanks and clean liquid tanks according to customer preferences, and automated liquid transportation can be carried out)

双系统保护蒸馏设备

Dual system protection distillation equipment



搅拌器选配
Mixer selection

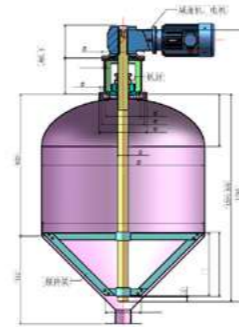

型号 Model	进料容量 Feed capacity	电源 (ACV) Power supply (ACV)	功率 Power	温度范围 temperature range	处理时间 Processing time	回收率 Rate Of Recovery	设备尺寸 Equipment size
T-260	250L	380	16KW	50°C -210°C	4-12H	95%-98%	3337*1358*2783mm
T-430	400L	380	32KW	50°C -210°C	4-12H	95%-98%	3627*1660*2775mm
T-600	600L	380	48KW	50°C -210°C	4-12H	95%-98%	2750*1768*3400mm

设备主要功能及简介:

- 1、水冷连续型溶剂回收机，进料 250-600 升，桶槽总容量为 320~700 升，连续进料，连续出料，中途自动补料，回收溶剂的 95% 以上。
- 2、气动加手动排渣双保护，桶槽厚度为 6MM，SUS304 不锈钢，排渣口为 DN100 气动阀。
- 3、控制系统两套，双向保护系统，即使一套系统故障，另一套系统起保护作用。
- 4、配置螺旋缠绕管式冷凝器，内管 316L，外壳 304 不锈钢，设备含声光报警装置。
- 5、配备导热油循环装置，导热油在设备中温度均匀受热，更安全。
- 6、电控部分采用西门子，施耐德，欧姆龙，SMC，E+H，等部件控制。
- 7、配备增高架，可直接将残渣排放至大桶中。
- 8、三菱 PLC 和三菱温度模组组合，温度可精确至小数点，也可选用西门子 PLC。

- 9、设备配备压力控制系统，当压力超过 0.04 兆帕，设备将停机并报警。
- 10、设备配备双 1 寸口径安全阀，保证桶内无压力。
- 11、设备配备电子式双温控系统，主系统损坏还有备用系统，防止设备超温带来的安全隐患。
- 12、配备氮气保护装置，将蒸馏罐 0 区转化为 1 区，更安全使用回收机。
- 13、配备空气检测装置及视窗灯。低于设定压力，设备停止加热并报警。
- 14、配备双液位控制，主控制采用德国进口 E+H 液位，加国产液位双保护。
- 15、桶内标配特氟龙涂层，锥形桶，排渣更方便。
- 16、可选配搅拌装置，让桶内受热更加均匀。
- 17、此设备经过德国巴斯夫，中国设计科学研究研评估安全产品。

Main functions and introduction of the equipment:

1. Water cooled continuous solvent recovery machine, with a feed volume of 250~600 liters and a total tank capacity of 320~700 liters. continuous feeding and continuous discharge, Midway automatic replenishment, recovering over 95% of the solvent.
2. Pneumatic and manual slag discharge dual protection, barrel groove thickness is 6mm, SUS304 stainless steel, slag discharge port is DN100 pneumatic valve.
3. Two sets of control systems, bidirectional protection system, even if one system fails, the other system will provide protection.
4. Equipped with spiral wound tube condenser, inner tube 316L, outer shell 304 stainless steel, equipment includes sound and light alarm device.
5. Equipped with a thermal oil circulation device, the thermal oil is uniformly heated in the equipment, making it safer.
6. The electronic control part is controlled by components such as Siemens, Schneider, Omron, SMC, E+H, etc.
7. Equipped with elevated structures, it can directly discharge residues into large barrels.
8. Mitsubishi PLC and Mitsubishi temperature module combination, temperature can be precise to the decimal point, or optional Using Siemens PLC.
9. The equipment is equipped with a pressure control system. When the pressure exceeds 0.04 MPa, the equipment will shut down and Alarm.
10. The equipment is equipped with dual 1-inch diameter safety valve to ensure no pressure inside the barrel.
11. The equipment is equipped with an electronic dual temperature control system. The main system is damaged and there is a backup system to prevent damage Safety hazards caused by equipment overheating.
12. Equipped with a nitrogen protection device, convert zone 0 of the retention tank into zone 1 for safer use of the recovery machine.
13. Equipped with air detection device and window light. Below the set pressure, the equipment stops heating and alarms.
14. Equipped with dual liquid level control, the main control adopts German imported E+H liquid level. Add domestic liquid level dual protection
15. Standard Teflon coating inside the bucket, conical bucket for easier slag discharge.
16. Optional mixing device to ensure even heating inside the barrel
17. This device has been evaluated as a safety product by BASF in Germany and scientific research in China.

T-1000 全自动连续型设备

T-1000 Continuous-type solvent recovery machine



型号 Model	进料容量 Feed capacity	电源 (ACV) Power supply (ACV)	功率 Power	温度范围 temperature range	处理时间 Processing time	回收率 Rate Of Recovery
T-1000	1000L	380	65KW	50-200°C	12-24H	95%-98%

产品详情:

此设备为全自动连续型溶剂回收机，配备导热油油封装置，进料容量 1000 升，设备总容量 1300 升，整体重量约 5 吨，每小时回收 300-400 公斤溶剂，适合废溶剂量较大的公司，耐腐蚀，耐盐酸，钛材料及不锈钢制造，设备带搅拌装置，带导热油循环装置，适合回收量大的公司使用。

Product Details:

This equipment is a fully automatic continuous solvent recovery machine, equipped with a thermal oil seal device, with a feed capacity of 1000 liters and a total capacity of 1300 liters. The overall weight is about 5 tons, and 300-400 kilograms of solvent are recovered per hour. It is suitable for companies with large amounts of waste solvents, corrosion resistance, hydrochloric acid resistance, titanium materials, and stainless steel manufacturing. The equipment is equipped with a mixing device and a thermal oil circulation device, suitable for companies with large recovery volumes.

T-430 全自动连续型设备

T-430 Continuous-type solvent recovery machine



型号 Model	进料容量 Feed capacity	电源 (ACV) Power supply (ACV)	功率 Power	温度范围 temperature range	处理时间 Processing time	回收率 Rate Of Recovery	机器尺寸 Machine dimensions	机器重量 Machine weight
T-430	400L	380	32KW	50-210	4-12H	95%-98%	3380*1470*2950mm	1000KG
T-600	600L	380	48KW	50-210	4-12H	95%-98%	2750*1768*3400mm	1500KG

产品详情:

1. 气动加手动排渣双保护，桶槽厚度为 6MM，SUS304 不锈钢，排渣口为 DN100 气动阀。
2. 防爆显示屏加防护罩，更安全，更快速回收的一款设备。
3. 配置螺旋缠绕管式冷凝器，内管 316L，外壳 304 不锈钢，设备含声光报警装置。
4. 配备导热油循环装置，导热油在设备中温度均匀受热，更安全。
5. 配备增高架，可直接将残渣排放至大桶中。

Product Details:

1. Pneumatic and manual slag discharge dual protection, bucket groove thickness of 6mm, SUS304 stainless steel, slag discharge port DN100 pneumatic valve.
2. Explosion proof display screen with protective cover, a safer and faster device for recycling.
3. Equipped with a spiral wound tube condenser, with an inner tube of 316L and an outer shell of 304 stainless steel. The equipment includes an audible and visual alarm device.
4. Equipped with a thermal oil circulation device, the thermal oil is uniformly heated in the equipment, making it safer.
5. Equipped with elevated structures that can directly discharge residues into large barrels.

PLC T-260 配置真空罐 PLC T-260 with vacuum tank



型号 Model	进料容量 Feed capacity	功率 Power	处理时间 Processing Time	重量 Weight	设备尺寸 Equipment size
T-260	250L	16KW	4-12H	530KG	2600*1200*1950mm

产品介绍:

PLC 控制型溶剂回收机，进料 200-250 升，桶槽总容量 320 升，桶壁厚 3.00MM，功率 16KW，采用三菱 PLC 或西门子 PLC 编程控制，整机防爆认证。

触摸屏控制，更直观方便，容易操作；可选配真空罐，成为负压蒸馏设备，可蒸馏 200℃ 以下沸点溶剂。

设备桶槽可选做直桶款设计，桶槽上下一样大小，方便套高温袋。

Product Introduction:

PLC controlled solvent recovery machine, with a feed capacity of 200-250 liters, a total tank capacity of 320 liters, the thickness of barral of 3.00MM, power of 16KW, using Mitsubishi PLC or Siemens PLC programming control, and a complete explosion-proof certification.

Touch screen control, more intuitive, convenient, and easy to operate; Optional vacuum tank, becoming a negative pressure distillation equipment, capable of distilling solvents with boiling points below 200 °C. The equipment bucket slot can be designed as a straight bucket, with the same size on top and bottom, making it convenient to fit high-temperature bags

T-260 全自动连续型设备 T-260 Continuous-type solvent recovery machine



型号 Model	进料容量 Feed capacity	功率 Power	处理时间 Processing time	机器尺寸 Machine dimensions	机器重量 Machine weight
T-260	250L	16KW	4-12H	2600*1200*1950mm	520KG

产品简介:

智能安全型回收机含真空泵机型，回收高沸点及易分解溶剂。标配压力控制系统，标配 1 寸大安全阀，视窗及防爆灯，可选配特氟龙涂层。此设备在第三代基础上，改进为杰兴 PLC 加欧姆龙温控系统，中英文显示，并将旋钮式温控改进为电子式温控，避免因旋钮式温控两年后弹片氧化，而起不到高温报警作用。

Product Introduction:

The intelligent and safe recycling machine includes a vacuum pump model to recycle high boiling and easily decomposable solvents. Standard pressure control system, Standard 1-inch large safety valve, window and explosion-proof light, Optional Teflon coating. On the basis of the third generation, Improved to JXEP PLC with Omron temperature control system, and has changed the knob type temperature control to electronic temperature control to avoid the inability to function as a high temperature alarm due to the oxidation of shrapnel after two years of knob type temperature control.

溶剂回收机流程图 Process diagram of solvent recovery machine

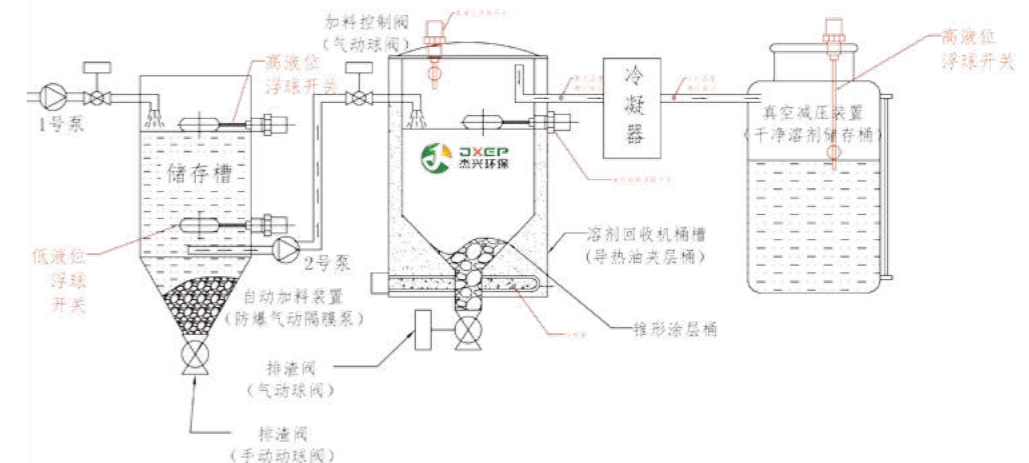

T-125 全自动连续型设备 T-125 Continuous-type solvent recovery machine



不锈钢冷凝器 (选配)
Stainless steel condenser (optional)

铜冷凝器 (标配)
Copper condenser (standard configuration)

加热器
Heater

杰兴 PLC 加中文显示系统
JXEP PLC with Chinese display system

型号 Model	进料容量 Feed capacity	电源 (ACV) Power supply (ACV)	功率 Power	温度范围 Temperature range	处理时间 Processing time	回收率 Rate Of Recovery	机器尺寸 Machine dimensions	机器重量 Machine weight
T-125	125L	380V	6KW	50-210°C	4-12H	95%-98%	1200*850*1450mm	280KG

机器特点:

- 整机与部件采用防爆安全设计，产品通过中国国家防爆监督检验中心检验合格产品：防爆合格证号：CNEEx23.4515X；并通过欧盟 CE 认证，平安公司承保产品责任险，产品专利等。
- 自主独立研发智能安全系统，欧姆龙温控 + 中文显示控制。
- 特制防爆操作机构，无需打开操作箱就能进行安全参数设定，适合在防爆环境下操作！
- 定时关机功能：设定机器回收时间，机器开机运行达到预设时长，设备将停止加热系统，风扇会继续运行约 20 分钟后，设备将自动停机。

Machine features:

- The entire machine and components adopt explosion-proof safety design, and the product has passed the inspection of China National Explosion Prevention Supervision and Inspection Center. Product: Explosion proof Certificate No.: CNEEx23.4515X; And pass the EU CE certification, Ping An Company underwrites product liability insurance, product patents, etc.
- Independently developed intelligent security system, with Omron temperature control and Chinese display control.
- Specially designed explosion-proof operating mechanism, allowing for safety parameter settings without opening the operating box, suitable for operation in explosion-proof environments!
- Timed shutdown function: Set the machine recovery time. When the machine reaches the preset running time, the heating system will stop and the fan will continue to operate. After about 20 minutes, the equipment will automatically shut down.

T-80 全自动连续型设备 T-80 Continuous-type solvent recovery machine



压力变送器
Pressure transducer

1 寸大安全阀
1 inch safety valve

型号 Model	进料容量 Feed capacity	功率 Power	处理时间 Processing time	回收率 Rate Of Recovery	机器重量 Machine weight	机器尺寸 Machine dimensions
T-80	80L	5KW	4-12H	95%-98%	230KG	1200*850*1290mm

产品介绍:

连续型回收机就是，一键启动，设备将自动进料，进满后设备自动停止，约半小时后开始流出干净溶剂，流出约 3-5 升，设备中的液位下降（配有液位浮球装置），此时设备会自动补料，可以设定 12 小时工作，连续的进料，连续的出料，全自动化运行，人员只需更换干净的桶和脏的溶剂桶即可。

Product Introduction:

A continuous recycling machine is a machine that starts with one key, and the equipment will automatically feed. When the feed is full, the equipment will automatically stop, and after about half an hour, clean solvent will start to flow out, with a flow of about 3-5 liters. The liquid level in the equipment will decrease (equipped with a liquid level float device), and the equipment will automatically replenish the material. That is to say, 12 working hours can be set, continuous feeding, continuous discharging, and fully automated operation. The operator only needs to replace the cleaned bucket and dirty solvent bucket.

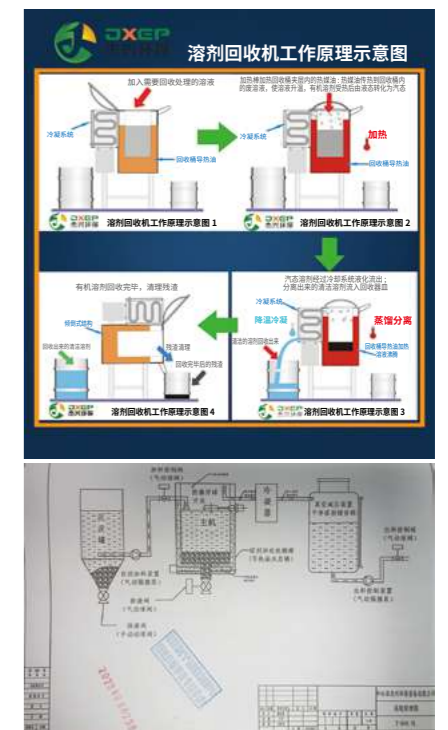

《此工作流程已在防爆检测中心备案》
This workflow has been filed with the explosion-proof testing center

T-60 全自动连续型设备 T-60 Continuous-type solvent recovery machine



定制款 T-60 连续型回收机
Customized T-60 continuous recycling machine

型号 Model	进料容量 Feed capacity	电源 (ACV) Power supply (ACV)	功率 Power	温度范围 Temperature range	处理时间 Processing time	回收率 Rate Of Recovery	机器尺寸 Machine dimensions	机器重量 Machine weight
T-60	60L	380V	4KW	50-200°C	4-12H	95%-98%	1020*750*1300mm	200KG

产品详情:

此设备为国产系统连续回收设备，在第三代回收机基础上增加安全配置及全自动进料系统，配置均外置。可实现倾倒排渣或下排渣。价格实惠，是溶剂回收机行业中性价比最高的一款设备，此设备配备：

- 1、压力控制系统
- 2、连续型进料系统
- 3、大型安全阀系列
- 4、欧姆龙温控 + 中文显示功能
- 5、选配视窗及灯功能
- 6、可选配威纶通触摸屏及防爆声光报警器

Product Details:

This equipment is a domestically produced continuous recycling equipment, which adds safety configuration and a fully automatic feeding system on the basis of the third-generation recycling machine, and all configurations are external. It can achieve dumping discharging or discharging by outlet. Affordable, it is the most cost-effective equipment in the solvent recycling machine industry, equipped with:

1. Pressure Control System
2. Continuous Feed System
3. Large safety valve series
4. Omron temperature control+Chinese display function
5. Optional window and light functions
6. Optional Weilun Tong touch screen and explosion-proof sound and light alarm

T-260/T-125 单次型溶剂回收机 T-260/T-125 single-type solvent recovery machine



减速机 Reducer

型号 Model	进料容量 Feed capacity	回收率 Rate Of Recovery	工作时间 Working Hours	重量 Weight	功率 Power	设备尺寸 Equipment size
T-125	125 L	95%-98%	2.5-4H	200KG	6KW	1200*850*1450mm
T-260	250 L	95%-98%	3-4H	520KG	16KW	2600*1200*1950mm

适合回收的溶剂:

适宜回收的溶剂溶液种类：甲苯、二甲苯、苯类、澳丙烷、二氯甲烷、环己烷、烷类、环己酮、丙酮、丁酮、四氯乙烯、三氯乙烯、甲醇、乙醇、异丙醇、乙醚、醋酸甲酯、醋酸乙酯、乙酸正丁酯、洗板水、洗车水、防白水、白电油、200# 溶剂油、挥发油、翅片油、航空煤油、D40-D-60 溶剂油、碳氢清洗剂，天那水，稀料等混合溶剂及未列出的其它有机溶剂。

Suitable solvents for recycling:

Suitable types of solvent solutions for recycling: toluene, xylene, benzene, propane, dichloromethane, cyclohexane, alkanes, cyclohexanone, acetone, butanone, tetrachloroethylene, trichloroethylene, methanol, ethanol, isopropanol, ether, methyl acetate, ethyl acetate, n-butyl acetate, plate washing water, car washing water, anti white water, white electricity oil, 200 # solvent oil, volatile oil, fin oil, aviation kerosene, D40-D-60 solvent oil, hydrocarbon cleaning agent, Mix solvents such as water, diluents, and other organic solvents not listed.

T-125 单次型溶剂回收机 标准机

T-125 single-type solvent recovery machine standard



型号 Model	进料容量 Feed capacity	回收率 Rate Of Recovery	工作时间 Working Hours	重量 Weight	功率 Power	设备尺寸 Equipment size
T-125	125L	95%-98%	2.5-4H	200KG	6KW	1200*850*1450mm

产品介绍:

风冷型溶剂回收机, 进料 125 升, 桶槽总容量为 150 升, 桶壁厚 2.5MM, 功率 6KW。改进旋钮式温控, 增加电子式温控, 功率小, 价格低廉, 增加大安全阀, 压力控制系统, 可选配特氟龙涂层, 大声光报警器, 不锈钢冷凝器等配置。

Product Introduction:

Air cooled-type solvent recovery machine, with a feed of 125 liters, a total tank capacity of 150 liters, a barrel thickness of 2.5mm, and a power of 6KW. Improved knob type temperature control, added electronic temperature control, low power, low price, added large safety valve, pressure control system, optional Teflon coating, loud and light alarm, stainless steel condenser and other configurations.

杰兴产品买的时候贵, 3-5 年无故障率, 你会选择便宜点的还是质量更好点的?

思路决定出路 我们梦想

成为全球第一的溶剂回收设备供应商

T-80 单次型溶剂回收机

T-80 single-type solvent recovery machine



型号 Model	进料容量 Feed capacity	回收率 Rate Of Recovery	工作时间 Working Hours	重量 Weight	功率 Power	设备尺寸 Equipment size
T-80	80L	95%-98%	2.5-4H	200KG	5KW	1200*850*1290mm

产品介绍:

单次型回收机也就是一锅一锅的做(回收), 比如人工或泵加入溶剂, 装满后人工停止进料, 开机, 将这一锅溶剂蒸馏完毕后, 自动停机, 也就是一次次的做, 需要告知您的是, 单次蒸馏完毕后, 设备需要冷却 1-2 小时左右, 冷却后, 方可打开盖子, 如未冷却, 散发出的气味可能会遭到投诉, 可能导致后期环保监督部门不让你使用这个设备。

Product Introduction:

A single cycle recycling machine, also known as a one pot one pot operation (recycling), involves adding solvent to the machine by manual or pump, filling it up, stopping the feeding process immediately, starting it, distilling the solvent from one pot to another, and then stopping it automatically. This means that after each cycle of operation, the equipment needs to cool down for about 1-2 hours. After cooling down, the lid can be opened. If it is not cooled down, The odor emitted may be subject to complaints, It may lead to the environmental supervision department not allowing you to use this equipment.

T-60 单次型溶剂回收机

T-60 single-type solvent recovery machine



高温袋
High temperature bag



报警器
Alarm

型号 Model	进料容量 Feed capacity	工作时间 Working Hours	功率 Power	温度范围 temperature range	回收率 Rate Of Recovery	设备尺寸 Equipment size
T-20	20L	2.5-4H	2KW	50-210°C	95%-98%	850*600*1200mm
T-60	60L	2.5-4H	4KW	50-210°C	95%-98%	1040*750*1300mm

产品介绍:

改进款设备在第三代的基础上增加了更多的安全配置，如：压力控制系统，1寸不锈钢安全阀，将电控箱内旋钮式温控改为电子式温控，防止旋钮式温控两年后因弹片老化而不起作用，改进后电子式温控与旋钮式温控不同一条线路，独立的温控+感温探头，独立控制设备温度，双温控控温，保证设备即使温控损坏，也不至于带来安全隐患。

Product Introduction:

The improved equipment has added more safety features on the basis of the third generation, such as a pressure control system, a 1-inch stainless steel safety valve, and electronic temperature control instead of rotary temperature control inside the electrical control box, to prevent rotary temperature control from becoming ineffective after two years due to aging shrapnel. The improved electronic temperature control and rotary temperature control have a different circuit, with independent temperature control and temperature sensing probe, independent control of equipment temperature, and dual temperature control, Ensure that even if the temperature control of the equipment is damaged, it will not bring safety hazards

双效蒸馏设备

Dual effect distillation equipment



双效蒸馏设备介绍:

1. 设备采用双罐蒸馏原理；A罐为常压蒸馏，B罐为负压蒸馏，双罐同时蒸馏技术，可浓缩80-90%，双罐蒸馏回收系统，节约用电，能量回收。
2. 采用两个罐子蒸馏法浓缩，防爆双层桶工艺，可回收含COD废水，水性切削液，水性废水，各类工业废水混合物等，排出的废液可进入常压罐再次蒸馏，可蒸干，减少危废的处理量，蒸馏后的水可以进入污水处理系统处理或再次清洗或使用水的地方使用。

Introduction to Double Effect Distillation Equipment:

1. The equipment adopts the principle of double tank distillation; A tank is for atmospheric distillation, B tank is for negative pressure distillation, and the dual tank simultaneous distillation technology can concentrate 80-90%. The dual tank distillation recovery system saves electricity and recovers energy.
2. Adopting two tank distillation method for concentration and explosion-proof double-layer barrel process, COD containing wastewater, water-based cutting fluid, water-based wastewater, various industrial wastewater mixtures, etc. can be recovered. The discharged waste liquid can enter the atmospheric tank for further distillation, which can be evaporated to reduce the amount of hazardous waste treatment. The distilled water can be treated in the sewage treatment system, cleaned again, or used in places where water is used.

T-125 耐腐蚀溶剂回收设备

T-125 corrosion-resistant solvent recovery equipment



导热油快速冷却系统
Heat transfer oil quick cooling system

产品介绍:

此款设备专为客户的废液中含有腐蚀性液体而生，废液中含有如氯离子，盐酸，硝酸，硫酸等酸性液体回收再利用，设备桶槽，封头，管道采用双相不锈钢，冷凝器采用玻璃冷凝器或钛冷凝器，设备从零部件到整机均有防爆认证，单次性回收，是含有腐蚀性液体回收的最佳选择。

Product Introduction:

This equipment is specifically designed for the recycling and reuse of acidic and alkaline liquids such as chloride ions, hydrochloric acid, nitric acid, sulfuric acid, etc. in the customer's waste liquid. The equipment barrel, head, and pipeline are made of duplex stainless steel, and the condenser is made of glass or titanium. The equipment has explosion-proof certification from components to the entire machine, and single recovery is the best choice for recycling corrosive liquids.



真空泵系列

Vacuum pump series



型号 Model	进料容量 Feed capacity	驱动方式 Driving method	重量 Weight	设备尺寸 Equipment size
X-80	90L	气动 Pneumatic	40KG	450*550*1300mm
X-125	130L	气动 Pneumatic	50KG	550*600*1350mm
X-250	300L	气动 Pneumatic	80KG	800*950*1880mm
X-500	400L	气动 Pneumatic	100KG	900*1050*1900mm

产品介绍:

- 1、配合溶剂回收机使用，用于回收高沸点和加热后易分解的溶剂。
- 2、有效降低溶剂沸点 30%-50%，完全密封，溶剂不外露，提高 30% 的回收速度，自动出料装置
- 3、配置 SMC 真空发生器
- 4、真空 ≤ 0.5 大气压力 (≤ 0.05Mpa) 约 600-650MMHG 增压 ≤ 2 个大气压 (0.2Mpa)

Product Introduction:

1. Used in conjunction with a solvent recovery machine to recover solvents with high boiling points and easy decomposition after heating.
2. Effectively reducing solvent boiling point by 30% -50%, completely sealed, solvent not exposed, increasing recovery speed by 30%, automatic discharge device
3. Configure SMC vacuum generator
4. Vacuum ≤ 0.5 atmospheric pressure (≤ 0.05Mpa) approximately 600-650MMHG Boosting ≤ 2 atmospheres (0.2Mpa)

定制款设备展示

Customized Equipment Display



- 可根据客户定制，废水低温蒸馏设备，溶剂脱水设备，溶剂低温蒸馏设备，设备带搅拌装置，带氮气保护装置，配置储罐高低液位，并输送至客户现场等非标定制化设备。

Customizable according to customers, including wastewater low-temperature distillation equipment, solvent dehydration equipment, solvent low-temperature distillation equipment, equipment with mixing device, nitrogen protection device, configuration of high and low liquid levels in storage tanks, and delivery to customer sites and other non standardized equipment.

- (图片中的设备包含的支架和楼梯尚未展示出来)

(The shelf and stairs included in the equipment in the picture have not been shown yet)

我们一直在努力解决工厂的废水问题
安全 耐用 便捷性 一直是我们奋斗的目标

客户见证和使用现场案例

CUSTOMER WITNESS AND ON-SITE USE CASES

